



hp storage

november 2002

hp Ultrium 2
technical white
paper

hp StorageWorks Ultrium 460 – technical white paper

executive summary

The Linear Tape Open Ultrium format developed by HP, IBM and Seagate has become the de facto standard in the “Superdrive” tape marketplace. Superdrives are generally considered to have a capacity greater than 100GB. In line with the roadmap (Fig.1) published at the product launch HP has now released the second generation of Ultrium tape drives and tape media. The Ultrium 460 tape drive using Ultrium generation 2 technology has a native capacity (without data compression) on a single tape of 200GB. This is twice the capacity of Ultrium 1 tape drives. The native transfer rate has increased from 15MB/s to 30MB/s. The Ultrium 2 format remains an open LTO standard, ensuring media interchange between any product which carries the Ultrium compliance mark. Award of the Ultrium logo means that drives or media have passed the strict compliance verification program. Ultrium 460 tape drives are fully read and write compatible with all Ultrium generation1 products. HP has incorporated many technical improvements in the new Ultrium 460 tape drives, which will further enhance their excellent reliability and performance in standalone or automation applications. Customers choosing HP StorageWorks Ultrium technology can utilize this advanced tape drive to secure the increased data volumes of modern servers in the most efficient manner.



Figure 1 - hp StorageWorks Ultrium 460 desktop version



..the need for speed

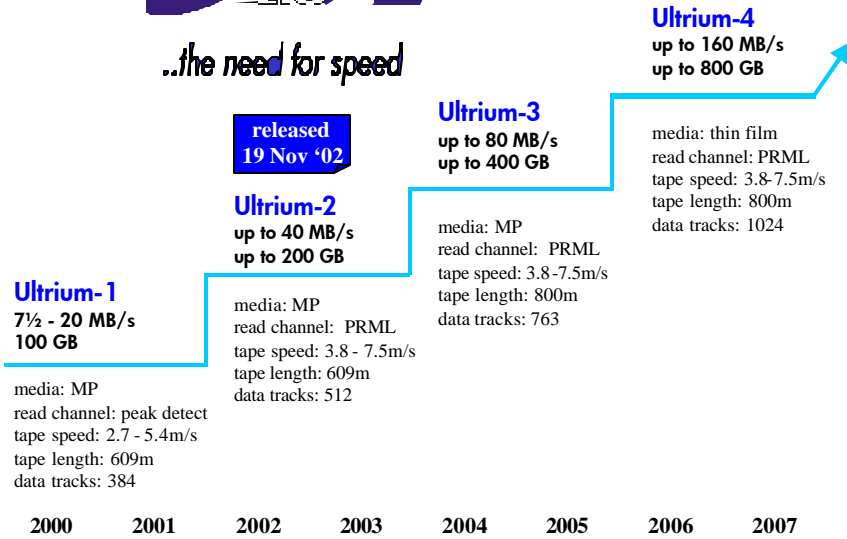

Figure 2- hp StorageWorks LTO Ultrium Technology Roadmap

what's new in the hp StorageWorks Ultrium 460 tape drive

As well as introducing the new LTO Ultrium 2 format, the Ultrium 460 tape drive incorporates many new advanced features which are new to HP StorageWorks Ultrium tape drives. These complement both the performance and the reliability of the drive and leverage from the successful HP StorageWorks 230 Ultrium 1 tape drive.



Figure 3- hp StorageWorks Ultrium 460 mechanism

new feature	benefits:
Ultrium 2 format capable drive with full backwards compatibility with Ultrium 1	increased native tape capacity to 200GB with greater throughput (30MB/s)
new HP StorageWorks Ultrium 2 media in a new color	easy cartridge format recognition. HP cartridge is dark red for Ultrium 2.
Ultra-160 SCSI interface (Ultra-3 SCSI) with dedicated interface microprocessor.	enables faster data transfers between the host system and the drive
new tape path and guide rollers	improved tape handling and packing at higher tape speeds
new tape drive controller design	greater reliability, performance and power efficiency
improved servo system	better data integrity at Ultrium 2 density
new vibration isolation mounts	improves the operating specifications – more robust performance under shock and vibration conditions.
new cartridge presence sensor	enables better tape handling in tape library applications
new front panels for stand alone and automation drives	better airflow keeps the drive electronics cool and with better diagnostic port access.
data head design improvements	necessary for the higher data density
enhanced adaptive tape speed (ATS) range for Ultrium 1 and Ultrium 2 tapes	reduces the number of tape re-positions due to 'stream' fail which improves performance and reliability
new PRML-4 read channel with Viterbi detector	digital signal processing enables increased data capacity with improved error rates.
data encoding changed to RLL 0,13/11	essential change to cope with the 30% increase in bit density
improved automation interface with surrogate SCSI capability*	greater automation flexibility and reliability

the LTO Ultrium 2 format

The new LTO Ultrium 2 format is similar to the Ultrium 1 format, but enables an increase in the native capacity of the tape cartridge to 200GB. This has been achieved by increasing the number of data tracks to 512 from 384 and to increase the linear data density along the tracks to 7.32kbits/mm (33% increase). The drive is also designed to read and write Ultrium-1 format data cartridges. The length of tape in an Ultrium 2 cartridge remains at 609m. The format of the tape is identified from the cartridge memory prior to tape load and the drive servo system programmed to the appropriate format. The maximum permitted tape speed implemented in the Ultrium 2 format has been increased to 7.25m/s (HP StorageWorks Ultrium 1 is 4.1m/s) in order to increase the sustained data transfer rate. The pre-recorded servo tracks are unchanged from Ultrium 1 and were designed from the outset to allow for a higher track density in later Ultrium formats. However, the servo control electronics have been "re-tuned" to deliver more accurate tracking of both formats.

Ultrium 2 is an 'open' format and any drive or media displaying the Ultrium 2 compliance mark must pass the strict compliance tests. This ensures full compatibility between tape drives and media from any vendor. The format is also designed so that backwards compatibility is maintained for future generations.

tape layout

The tape is divided up into seven regions, which are marked by eight logical points. There are 5 servo tracks and 4 data bands. The servo tracks are pre-recorded when the tape is manufactured and cannot be erased. Figure 3 shows the location of the logical points on the tape.

When a tape is loaded the cartridge memory is read and the tape will load to the start of the user data region. The use of the calibration area is not defined in the format so does not take part in interchange. It may be used to set up write currents if desired. As the tape crosses LP1 it will lock on to the servo tracks in preparation for having the data heads correctly positioned at the beginning of the user data. The format identification data set (FID) and contains data extracted from the cartridge memory. The FID is written on initial cartridge load and can be used by the drive if the cartridge memory fails.

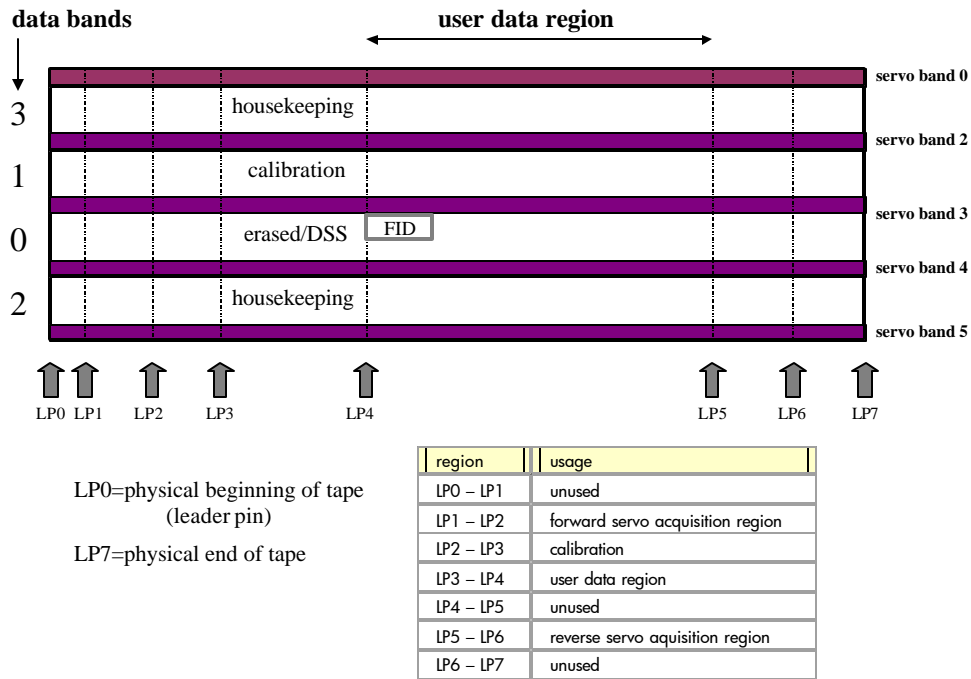

Figure 4- Ultrium 2 format tape layout

The position of the data heads along the tapes is calculated from the difference in the reel speed. The drive will be informed of the tape length by the cartridge memory.

Ultrium 2 Servo system

The servo system in the HP StorageWorks Ultrium 460 drive is designed to handle Ultrium 1 and Ultrium 2 tapes. Although there are no changes in the servo track layout it is worth discussing the servo system to fully understand its importance in the Ultrium 460 tape drive.

The timing based servo system in the Ultrium tape system is the key to the format and provides accurate information on the speed of the tape and the position of the read write head in relation to the data track locations on the tape. An embedded code system within the servo track provides constant information on how far the servo head is down the tape. The Ultrium 2 tape format defines 512 data tracks in total and 5 servo bands. The system is what is known as a 'closed-loop' servo system. The Ultrium-2 servo and data head assembly is mounted on moving carriage, which is driven by a linear actuator (fig 5). A variable inductance position transducer is used to position the heads when no servo signal is available. (tape load, direction change etc)

The Ultrium-2 servo bands are identical to those used in the Ultrium 1 format. There are 5 servo bands pre-written onto the tape at manufacture (Fig. 4). A servo band is located on either side of the data bands and using the signal read by the servo MR heads the actuator is moved to locate the MR read/write heads on the desired track. The servo tracks contain a set pattern designed so that by timing the period between magnetic fluctuations a position signal is derived. The tracks are arranged so that a two servo heads are used at all times. This builds some redundancy into the servo system in case of servo

signal loss. The average signal is taken from the two servo heads, one above the data band and one below. There are 4 active servo heads and the second pair is offset so that when traveling in the reverse direction down the tape the data tracks are located in new positions. It is arranged so that the drive starts to write tracks in the centre of the tape and works outwards in a serpentine fashion. Active servo elements are always arranged to be on the opposite head 'bump' to the read/write elements. This helps prevent interference from the write head elements. Fig. 4 shows how the data bands are arranged on the tape. For ease of manufacture there are actually 8 servo elements built into the head stack, 4 on each bump. In normal operation only 4 are used, 2 heads being used in each direction. During calibration and certain error recovery routines the other heads can be used.

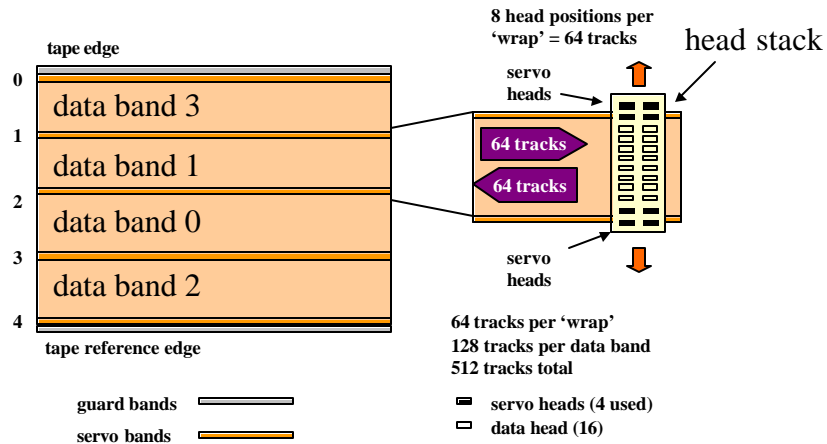

Figure 5- Ultrium 2 format servo and track detail

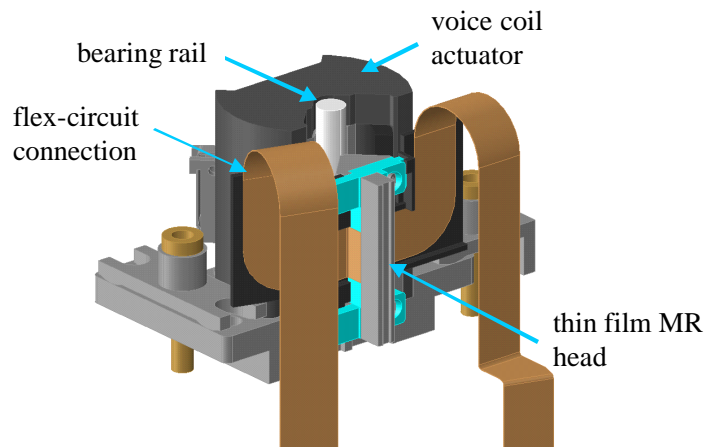

Figure 6- hp StorageWorks Ultrium actuator mechanism

Each servo band consists of magnetic stripes arranged as in Fig. 6. The servo bands are much wider than the head element. They are arranged in frames of 18 stripes in sets of 5 and 4 in a 5544 sequence. This sequence is used to aid identification of the servo frames.

The servo tracks provide information from which the head position across the tape path, tape speed and longitudinal position is derived. The head position is derived by timing the pulses A1-B1, A2-B2, A3-B3 and A4-B4. The mean time from these signals is used in conjunction with the signal from the other servo head, which is located above the other servo band. (Remember there are always two servo heads positioned on servo bands above and below the data tracks). Four timing signals A1-C1, A2-C2, A3-C3 and A4-C4 are used to measure the tape speed. In Ultrium 2 there are 8 head positions derived from each pair of servo bands when traveling in one direction down the tape. This is called a 'wrap'. When the tape reverses at the end of the tape the other two servo heads are used. Because these heads are offset they can define 8 different head positions for the reverse 'wrap'. Ultrium-1 format derives only 6 head positions per wrap. Track trimming is used in Ultrium 2 format which means that each subsequent set of tracks is slightly overlaps the adjacent tracks. This ensures that no space is lost 'between' adjacent tracks. If a servo signal is unreadable during write operations then the drive will post a check condition and an error status but if the operation is read only then it continues operations. In order to identify servo bands the servo bursts are offset from each other. Having one servo head positioned in each band, the relative offset of the signals identifies which data band the head is positioned over.

The servo stripes are also used to define the longitudinal position, (LPOS) . This is achieved by shifting the position of the 2nd and 4th stripe in the A and B servo sub-frames. Because both the A and B sub-frames do this, the relative timings are unchanged so that the head position and speed measurements are unaffected. A complete LPOS word is derived from 36 servo frames. The LPOS information is pre-written when the servo tracks are written during tape manufacture. The longitudinal position is just a number which increments steadily along the track. When a tape cartridge is first loaded the LPOS information is written to the cartridge memory. This enables BOT to be located in each subsequent cartridge load. The LPOS number is also used to encode information such as tape vendor ID within the servo information. Because the LPOS information is known to the drive 'drop ins' are prevented. "Drop ins" occur when there is a head clog on a write channel and old data is left on the tape. In Ultrium tape drives this is immediately identified and the appropriate action taken.

The HP StorageWorks Ultrium 460 tape drive will operate in Ultrium 1 or Ultrium 2 mode. This is determined from the cartridge memory and the appropriate changes are made to the servo electronics to produce the correct track pitch, number of tracks and linear density. If cartridge memory fails the drive will try and read the FID information using both formats in turn. This can take some time but the cartridge can still be read once the format has been identified.

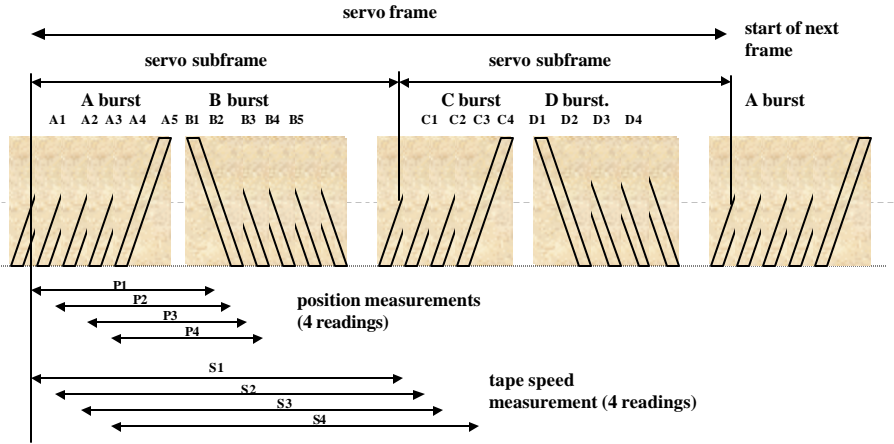

Figure 7- Ultrium format servo band detail

hp StorageWorks Ultrium 460 controller electronics

The new HP StorageWorks LTO Ultrium-2 tape drive has a completely new electronics module. This includes several new ASICs (Application Specific Integrated Circuits), which are required for the new format. Using experience gained in designing the Ultrium 1 tape drive, HP has been able to engineer even greater standards of performance and reliability. The controller electronics are located on a module located beneath the drive mechanism. The controller block diagram is shown in Figure 8.

At the heart of the control electronic is an NEC v851 microprocessor, which executes instructions held in 'flash' memory. This can be easily updated via the SCSI interface from the host system or using a specially created firmware update tape. The interface electronics is controlled by a separate microprocessor (Atmel ARM9). The use of a separate interface microprocessor is a major change from the Ultrium 1 tape drive where the interface electronics were controlled from the main microprocessor. The controller electronics also provide a serial RS422 automation control interface, a user interface (4 LED indicators and tape unload button) and an additional serial port for manufacturing test purposes. Separate ASICs are used for the interface, servo system, formatter, digital signal processor and read/write pre-amplifiers. 64MB of SDRAM is used as the main data buffer. (The HP StorageWorks Ultrium 230 drive has 16MB buffer). The data flows through the controller is as follows:

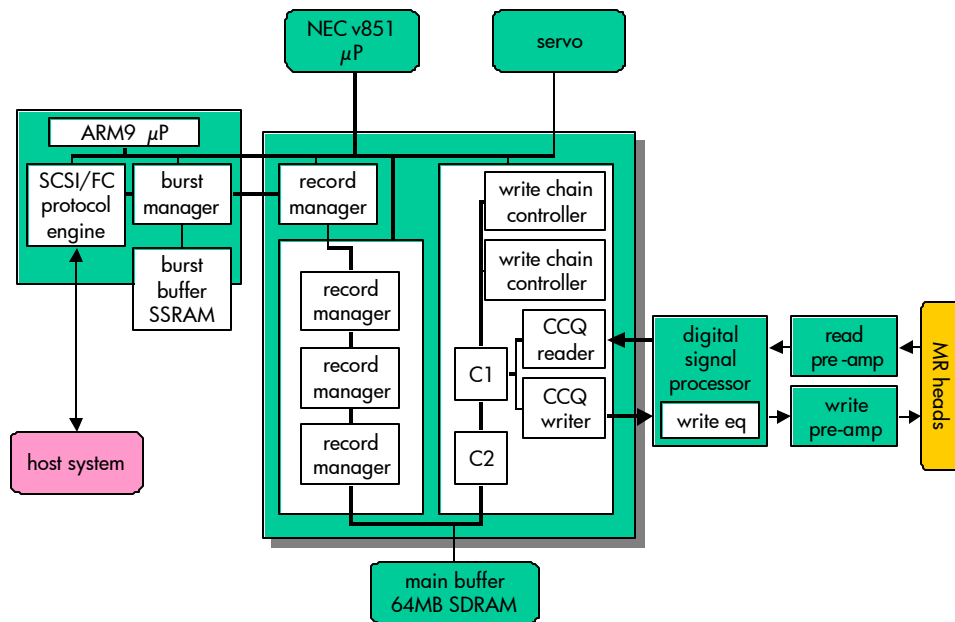

Figure 8- hp StorageWorks Ultrium 460 controller block diagram

writing data to tape

Data is received from the host interface via fibre channel or Ultra-160 parallel SCSI. The data will arrive in fast bursts of data depending on the setup of the host software, and is held in the burst buffer (SSRAM). The fibre channel versions have a larger burst buffer of 512KB, which is external to the ASIC. This is to allow for the faster data rates of a 2Gb/s fibre channel. The SCSI version of the drive has a 256KB burst buffer. The main purpose of this buffer is to isolate the high speed 'burst' nature of the SCSI data from the rest of the controller electronics. It should not be confused with the main drive buffer which is 64MB but is not located in the interface electronics. Data is taken from the burst buffer by the formatter and has record boundaries added. Data then has a CRC record added. The CRC is to ensure that no errors remain undetected by the formatter process. The data is compressed by the ALDC core as described earlier and has a C1 parity data added before being stored in the main buffer. This ensures that errors in the main buffer memory in case of data corruption by the SDRAM. The purpose of the 64MB main buffer is to provide a steady flow of data to the recording electronics. The data is then taken from the main buffer and has powerful C2 Reed Solomon codes added. Before passing the data to the CCQ writer the C1 error detection picks up any errors, which may have occurred in the main buffer SDRAM. The CCQ writer (CCQ=codeword quads) then randomizes that data to remove long sequences of ones or zeros. The data is then encoded using a Run Length Limited code. Because of the higher linear density a different RLL 0,11/13 code is used for the Ultrium-2 format. Of course the electronics will use the Ultrium 1 RLL(1,7) code when writing to Ultrium1 tapes. The signals are then subject to 'write' equalization before being applied to the write head elements via the write pre-amplifier. Remember 8 channels are written at the same time on 8 tracks. The data is immediately read by the 8 read elements on the trailing head 'bump' and sent back via the digital signal processor to the physical formatter. If the C2 code is in error then the data block is re-written on the tape. This is known as a read-while write retry. The data block re-writes are always on a different channel so that small media defects are easily handled.

reading data from tape

The read process is basically a reverse of the write process. The magnetic signal is retrieved from the tape by the 8 MR elements of the tape head. (Note that the servo code is always being read and fed into the servo system). The analogue data is amplified and filtered before being fed into the digital signal processor ASIC. The signal is then sampled at intervals and an analogue to digital converter used to convert the waveform into sets of 8-bit numbers. The Viterbi detector uses maximum likelihood techniques used to recover the data. The data is passed to the formatter, which decompresses and restores the data to its original form and sends it to the SCSI or fibre channel interface electronics.

MR Read-Write Heads

There are only minor changes in the magneto-resistive head design from those used in the HP StorageWorks Ultrium 1 product. In order to handle the higher frequencies of Ultrium 2 format the number of write coil turns has been reduced. The write gap is reduced from 1.2µm to 0.7µm in order to achieve the higher linear density. The write track width was not reduced from 27.5µm but 'track trimming' (overlapping adjacent tracks) used to reduce the track width to 20.2µm. The heads are a 2 bump self-cleaning design with magneto-resistive (MR) read heads and inductive write heads. The heads also have to write and read Ultrium 1 format tapes and no second head stack is required for backwards compatibility.

hp StorageWorks Ultrium 460 PRML read channel

The read channel of the HP StorageWorks Ultrium 460 uses Partial Response Maximum Likelihood (PRML) technology to recover the data signal from the tape. This well established technology is essential in order to recover data at the densities used in the Ultrium 2 format. PRML has been used to increase the capacity of disk drives for many years. The Ultrium 230 drive uses a peak detect method of recovering the digital data from the analogue, signal and although well capable at this data density is not sufficient for Ultrium 2 data densities. To describe the read channel it is necessary to understand a little of how the data is encoded before it is written to tape. After data compression and adding the Reed Solomon error correcting coding the data is in the form of codeword quads (CCQ). Reed Solomon encoding is a well-known block code, which has excellent error recovery methods. The data is then run through a data scrambler, which removes long strings of zeros. These are undesirable when writing magnetic information, as the read head output is proportional to the rate of change of magnetic flux. The data is then encoded using a run length limited code, before equalization and then turned into a write current. Ultrium 1 format used a RLL 1,7 code but this has changes in Ultrium 2 to a RLL 0,13/11 code. This will encode no more than 13 consecutive bits as a zero before changing state and no more than 11 consecutive interleave bits. This is more suitable to magnetic flux changes at double the density of the Ultrium 1 format. It is important to note that 8 channels are encoded simultaneously as the Ultrium 2 drive uses an 8 channel head.

The bit stream is now written onto the data tracks by the write heads. The read head recovers the signal from the tape but is subject to electrical 'noise' from the media. As well as noise the density of the flux changes in relationship to the data head 'gap' causes inter-symbol interference which peak detect systems cannot handle. The signal is amplified and subject to equalization so that the frequency response is more even. The data is written with a 'clock' signal, which is recovered from synchronization bursts, which occur at intervals in between data signals. A phase lock loop system is used to maintain this signal. The clock signal informs the read decoder the position of the bit cell transitions. The signals are shown in Fig 9 with a typical bit stream. The signal is then sampled at the intervals provided by the phase locked loop and is turned into a 36 bit digital number. This is the partial response part of the process. The signals are then digitally filtered. An advanced Viterbi detector is used to maintain a history (36 bit long, 16 states wide). The Viterbi detector makes decisions on the data sequences received, based on the history it has built up. It operates in a similar fashion to a person reading a document with spelling mistakes, but still being able to accurately understand the text. Any errors would of course be corrected by the powerful C1 and C2 Reed Solomon error correction, which is used after decoding.

After the Viterbi detector the digital bit stream is decoded from the run length limited code and unscrambled. The signals can then be returned to the formatter and after de-compression returned as blocks of real data to the I/O system. The advantage of this system is that it can also recover Ultrium 1 format signals as the digital filtering can be re-programmed and the decoding changed to cater for RLL 1,7. The drive identifies an Ultrium 1 tape from the cartridge memory system.

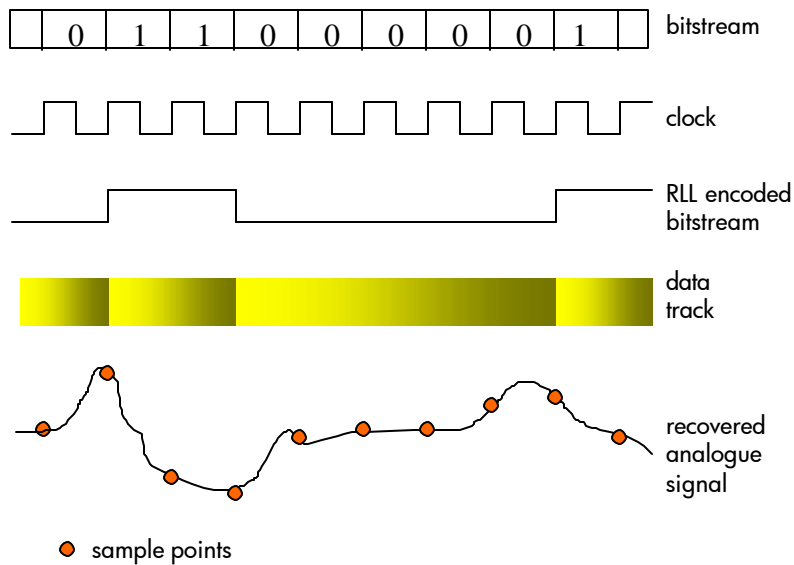

Figure 9- hp StorageWorks Ultrium 2 – PRML data sampling

ALDC data compression

The data compression method used in Ultrium technology is defined in the format. Therefore all vendors must use the ALDC algorithm for data compression. There is no change in the Ultrium 2 format standard. ALDC stands for Advanced Lossless Data Compression and is an implementation of the Liff Zempel method of compressing data. ALDC can be implemented in hardware more efficiently than the standard DCLZ method of data compression. In itself ALDC does not compress data any more efficiently than the DCLZ method, but has the ability to switch into a non-compressed mode according to the structure of the data pattern. This means that highly random data does not actually expand when compressed. ALDC in the HP StorageWorks Ultrium 460 tape drive is implemented in hardware within the formatter ASIC before data is sent to the main input/output data buffer.

The stream of data is received from the SCSI interface electronics and read into a 1K buffer. The data by this time is in the form of records. The data is read into a shift register. The data is output from the buffer as either 'literals' or copy pointers. The literals are 9 bits in length with the most significant bit set to 0. The copy pointers have the most significant bit sent to 0 and then contain a length variable and an address within the shift register. The shift register is 1K x 9 bit words. At record boundaries the process is reset and started over again. The compression rates are monitored and if compression is not being achieved the drive switches modes and only literals are put into the data stream. When data is found to be compressible the compression is turned back on.

Adaptive Tape Speed (ATS)

The Ultrium 460 tape drives uses a feature known as 'adaptive tape speed' which can dynamically vary the speed of the tape according to the data flow rate to or from the host system. This technology was successfully used in the Ultrium 1 tape drives and has now been enhanced in the Ultrium 460 tape drive. The extended range of operation has been extended for Ultrium 1 and Ultrium 2 format tapes.

The objective of the adaptive speed algorithm (ATS) is to minimize the number of re-positions performed by the tape mechanism. A reposition happens when there is either insufficient data from the host or when the host cannot accept the data from the drive. After stopping the tape drive has to reverse direction go back beyond where the last data was and then go in the forward direction again. Re-positioning the tape wastes time and causes extra wear on the media and tape mechanism. Adaptive tape speed continually monitors the host data rate and calculates a 'set point' within the main data buffer at which the speed of the tape is varied in order to maintain the level of the data within the buffer. The set point

position varies according to the data rate and when the end of wrap approaches. At the end of wrap during write, the drive will ensure the buffer is nearly empty if possible so the buffer space holds data while the tape turnaround is executed. During a restore the ATS system will keep the buffer nearly full before the end of wrap so that data flows out of the buffer back to the host. The main buffer on the HP StorageWorks 460 tape drive is 64MBytes. (HP StorageWorks Ultrium1 drives are 16MB). The adaptive tape speed range for the Ultrium 460 drive is 10 – 30MB/s for Ultrium 2 tapes and 6.6-20MB/s for Ultrium 1 format tapes (in HP StorageWorks Ultrium 2 drive). The differences in ATS ranges are because of the different data throughput for each format. (Ultrium 2 has greater tape speed and data density). The range of the ATS feature is dictated by read & write channels ability to cope with the bandwidth of the read/write channel. (The read signal below a certain speed would be too low and at high speeds the frequency starts to hit limits)

Of course, if the host data rate is out of the ATS range, the buffer will be used until eventually the tape must stop and a re-position is necessary. The clever feature is that ATS is dynamically adaptive and does not sit at a fixed buffer level. ATS makes the Ultrium 460 ideally suited for backup over a network where data rates can vary.

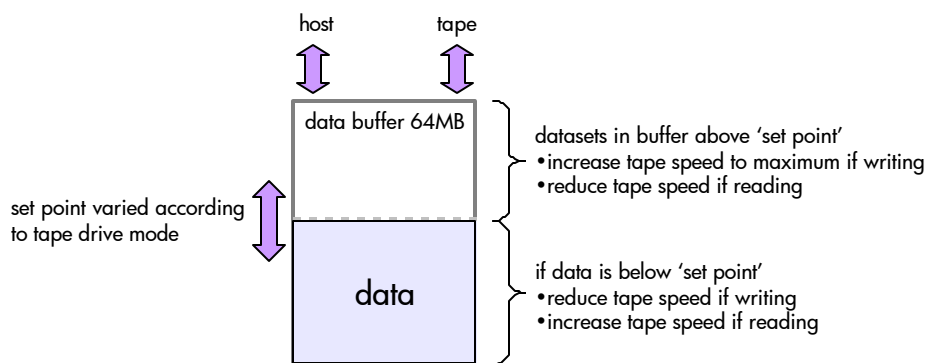

Figure 10- hp StorageWorks Ultrium 460 data buffer control

hp StorageWorks Ultrium 460 tape mechanism changes

The Ultrium 460 tape mechanism is based on the Ultrium 230 mechanism but has several major modifications. The tape path has been changed with new zirconium nitride coated roller, a new take-up spool with a reversed tape direction. These improvements reduce tape wander at the higher speeds of the Ultrium 2 tape and produce a better tape 'pack'. (Tape pack is the name for tape wound onto a spool) This is beneficial to tape life and reliability. Fig 11 shows the new tape path in the Ultrium 2 drive. The new path applies to both Ultrium 1 and Ultrium 2 tapes. The improved tape path also enables 're-tuning' of the servo system necessary for the increased data density of the Ultrium 2 format.

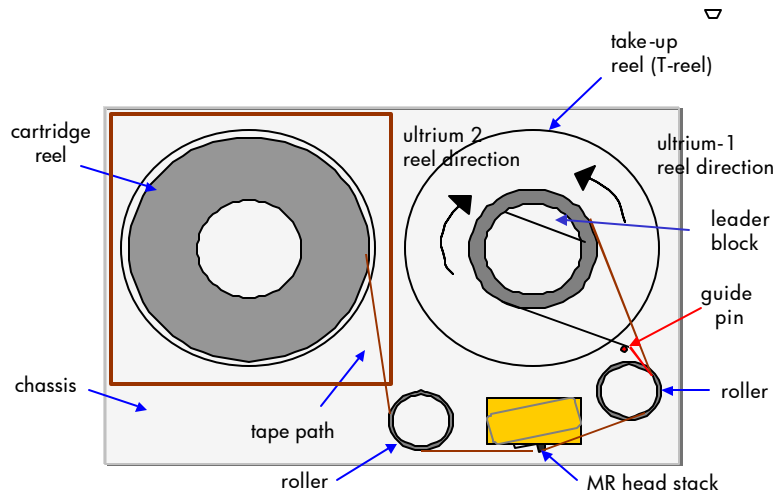

Figure 11- hp StorageWorks Ultrium 460 modified tape path

The external mounting of the tape mechanism chassis has been improved with new flexible mounts, which provide better vibration isolation. The Ultrium 460 drive has a better shock & vibration specification.

cartridge presence sensor

A new cartridge presence sensor has been added to the Ultrium 460 tape mechanism. In the previous Ultrium 230 tape drive a cartridge was only detected when it was pushed into the mechanism. This is advantageous for tape drives used in automation as it removes the need for the 'picker' mechanism to push in the cartridge. The tape cartridge can be placed in the slot and then the drive can be instructed via the ACI port to 'load' the cartridge. This can be used to increase the reliability of tape automation mechanisms. The sensor is located at the front of the drive on the cartridge memory reader assembly. This is a great benefit in automation and can identify mechanical faults to the library controller.

front panels

Two new front panels have been designed, one for the standalone drives and the other for automation. The LED indicators and the eject button switch are now located on the drive mechanism which removes the need for the ribbon cable from the front panel to the drive electronics. This is a key benefit for customization of the drive, which is important in the OEM and mechanism markets. The automation front panels also include access to the serial data port for diagnostic use and access to a reset switch. The air vents have been re-designed to provide better cooling for the drive electronics, while keeping the airflow away from the tape drive mechanism.

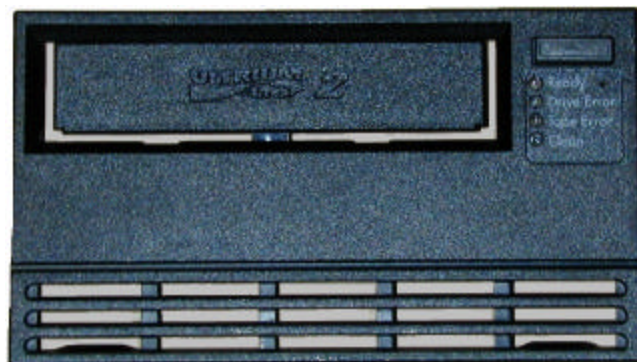

Figure 12- Ultrium 460 front panel

controls and indicators

The controls and indicators of the HP StorageWorks Ultrium 460 drive are very similar to the Ultrium 230 drive. The front panel has 4 LED indicators, one eject switch and concealed reset switch (accessed through a small hole). The LEDs have virtually identical meanings except that if the microprocessor fails to initialize all the LEDs are off. (This is the opposite sense to Ultrium 230 drives where all the LEDs stay on if the microprocessor fails to initialize). There is a power on self-test which is executed every time the drive is switched on. A failure is indicated by the yellow LEDs. There are separate LEDs for drive error and tape error. This allows the drive to identify a problem, which could be the media. The 4th LED is used to request the cleaning cartridge. The Ultrium 460 user guide fully documents the LED sequences.

hp StorageWorks Ultrium 2 media

New HP StorageWorks Ultrium-2 media in a dark red cartridge has been developed for Ultrium 2 drives. Although the tape length is identical to Ultrium 1 the formulation is new and has increased coercivity. These changes are necessary, as Ultrium-2 has increased bit density and tape speed.

The cartridge memory system although identical in size to Ultrium 1, is re-programmed with the new Ultrium 2 tape parameters. Changes are made to the entries for cartridge type and media speed with a new entry for optimal recording current.

The Ultrium 2 drives are compatible with Ultrium 1 and Ultrium 2 media as shown in Table 1 below.

media format	native tape capacity ¹	Ultrium 1 tape drive		Ultrium 2 tape drive	
		read	write	read	write
ultrium-1	50GB	yes	yes	yes ²	yes ²
ultrium-1	100GB	yes	yes	yes ²	yes ²
ultrium-2	200GB	no	no	yes	yes

Table 1 - Ultrium media compatibility

note 1- HP and other vendors of Ultrium Data Cartridges quote the compressed capacity assuming a 2:1 compression ratio.

note 2- Ultrium 2 tape drives read and write Ultrium 1 cartridges at 20MB/s (this is faster than the 15MB/s transfer rate of HP Ultrium 1)

hp StorageWorks media product numbers:

Ultrium-2 cartridge (200GB native) - C7972A

Ultrium-1 cartridge (100GB native) - C7971A

Universal cleaning cartridge - C7978A

The 50GB Ultrium-1 cartridge (C7970A) is no longer available.

Media from other manufacturers:

All media displaying the Ultrium-1 or Ultrium-2 compliance marks (as shown below) are fully supported in HP drives. HP does not recommend using non-HP branded cleaning cartridges.



Figure 13- hp StorageWorks Ultrium-2 media

interfacing the hp StorageWorks Ultrium 460

The Ultrium 2 tape drive has a completely new interface design. The interface is designed to be available in two standards: SCSI-3 parallel (SCSI SPI-3) and fibre channel. (Note: fibre channel version is initially only available to the OEM channel and will be aimed at automation vendors). Both interface versions are controlled by an ARM9™ microprocessor, which can operate independently from the main tape drive microprocessor. Two new ASICs (application specific integrated circuit) have been developed, one for fibre channel and one for parallel SCSI.

SCSI-3 parallel interface

This version is available for both desktop, internal and rack versions of the drive and is capable of transferring data bursts at 160MB/s. This standard is commonly referred to as Ultra-160 SCSI. This is a low voltage differential SCSI interface (LVD); and high voltage differential SCSI is not available. The desktop version has a dual 68-pin high density connectors fitted and has automatic bus termination. The maximum cable length to the host bus adapter when running at this speed is 12 meters. All parallel SCSI implementations above Ultra SCSI are wide 16-bit only. The internal Ultrium 2 drive has an SCA-2 connector, which is compatible with internal SCSI-3 cables. Termination is not provided by the internal Ultrium 2 drive. Termination power is selected by two jumpers, which are alongside the address jumpers. Termination power is 'ON' by default.

When configuring interfaces a recommended block size of at least 128KBytes should be used. The SCSI-3 interface on the Ultrium 2 drive has a 'burst buffer' size of 256KBytes but some of the buffer is used for internal purposes. In normal circumstance the SCSI bus will not disconnect until 96KB of data has been received from the host. The protocol at this level is handled by the host bus adapter itself without any host intervention and causes no overhead. However a large block size is essential for good performance. The burst buffer is not to be confused with the main buffer which is 64MB.

fibre channel interface

A class 3 fibre channel version of the Ultrium 2 drive has been developed for the tape automation market. This interface uses the same ARM9™ microprocessor but uses a custom ASIC and a Qlogic™ FAS490 dual port fibre channel controller. The physical interface is a dual LC type fibre optic connector, which can autosense 1Gb/s or 2GB/s. A larger 512KB buffer is available on the fibre channel interface. The fibre channel interface manager implements the FC-AL-2 protocol.

The interface will support a fabric login or loop connection. On power-on if connected to fabric the drive will attempt a fabric login.

Automation Control Interface (ACI)

In addition to the main drive interface, a RS422 serial interface is provided for automation control. This enables tape libraries and autoloader to send and receive information from the tape drive independently from the SCSI interface. The ACI port is on the rear of the drive and uses a PH-9 type of connector.

surrogate SCSI

Surrogate SCSI allows the SCSI commands to the library from the host to be routed via the SCSI interface of the drive, thus saving on the cost of a separate SCSI interface for the library controller. Typically, the drive will be assigned LUN 0 and the library controller will be assigned LUN 1 at the same SCSI address.

The drive acts as a conduit for the commands from the host to the library controller and passes the commands directly to the library controller via the ACI link. The status or data in turn is passed from the library controller to the host via the ACI link and the tape drive SCSI interface.

conclusions

This paper has discussed the new features of the HP StorageWorks 460 tape drive. The new Ultrium 2 format delivers capacity, speed and reliability and is fast becoming the de facto standard technology in the Superdrive marketplace. The roadmap uses well-established technology that ensures that each subsequent generation of LTO Ultrium is fully compatible to the standard, protecting investment for the customer. The Ultrium compliance certification ensures full compatibility between drives and media.

Further information on hp StorageWorks Ultrium tape products

<http://www.hp.com/go/connect>

<http://www.hp.com/storage>

<http://www.lto-technology.com>

Performance Assessment Tools can be downloaded from:

<http://www.hp.com/support/pat>

Table 2- specifications

hp StorageWorks Ultrium 460 – Product Specifications		
		notes:
Product Numbers		
Internal drive	Q1508A	Internal 5 ¼" FH
External drive	Q1509A	Desktop unit
Rackmount drive	Q1512A	Tape Array module
Trade Ready mechanism	Q1511A	
ProLiant internal	Q1518A	
ProLiant external	Q1519A	North America only
ProLiant external	Q1520A	World except N America
Performance		
Capacity (native)	200GB	
Sustained transfer rate	30MB/s (native)	60MB/s assuming 2:1 compression ratio.
Burst transfer rate	160MB/s	Ultra-3 SCSI
Variable length transfer length	16M –1 Bytes	
Data compression engine	132MB/s maximum	
Average file access time (from BOT)	52s	Ultrium-1 and Ultrium-2 tapes
Load to BOT	19s	Ultrium-2 tape
Unload from BOT	19s	Ultrium-2 tape
Rewind time	84s	Ultrium-2 tape
Rewind tape speed	7.25m/s	
Reposition time	TBA	
Uncorrectable error rate	1 in 10 ¹⁷ bits	
Undetected error rate	1 in 10 ²⁷ bits	
Reliability		
MTBF	250,000 hours at 100% duty cycle	
Head life	60,000 hours	
Load/unload life	100,000 cycles	
Format		
Recording format	Linear Tape Open Ultrium 8 channel	U28 specification
Data compression	ALDC	Standard in LTO Ultrium format.
Data encoding method	(0,13/11) RLL	
Channel technology	PRML-4 with advanced Viterbi detection	(Ultrium 1 was peak detect.)
Data channels	8	
Environmental		
Operating Limits		
Temperature	10 - 35°C	
Humidity (RH non-condensing)	20 - 80%	
Wet bulb temperature	26°C	
Temperature gradient	< 10°C per hour	
Operating altitude	0 to 4km	

Airflow	0.17m ³ per minute (6cu ft/min)	Positive airflow must be maintained
Suspended particles	<200µg/m ³	
Non-operating limits		
Temperature	-40° to 66°	
Humidity	10% to 95%	
Temperature rise	20°C/hour	
Humidity rise	30%/hour	
Non-operating altitude	0 to 15.25km	
Noise		
Operating acoustic noise	< 5.0 bel sound power	
Power requirements		
Internal version		
DC power requirements	+5V @ 2.0 A (idle)	Rated value: +5V 3.5A +12V 1.9A
	+12 V @ 0.4 A (idle)	
	+5 V @ 3.2 A (max)	
	+12 V @ 0.6 A (max)	
External version		
Rated value	100 – 240VAC 50/60Hz 0.7A max.	Auto-ranging. Power connection IEC 320